

Quick Reference Guide

Model No. KX-T7667

Important Information

- If you are having problems making calls, unplug the extension and connect a known working telephone. If the known working telephone operates properly, have the defective telephone repaired by an authorized Panasonic Factory Servicenter. If the known working telephone does not operate properly, check the KX-TDA series Business Telephone Systems and the internal extension wiring.
- Keep the unit away from heating appliances and devices that generate electrical noise, such as fluorescent lamps, motors and televisions. These noise sources can interfere with the performance of the unit.
- This unit should not be placed in rooms where the temperature is less than 5 °C (41 °F) or greater than 40 °C (104 °F). Allow 10 cm (3-15/16 in) clearance around the unit for proper ventilation.
- Avoid environments with excessive smoke, dust, mechanical vibration, shock, or direct sunlight.
- Wipe the unit with a soft cloth. Do not clean the unit with abrasive powders or with chemical agents such as benzine or thinner.
- Use only the correct Panasonic handset.
- Do not disassemble this unit. Dangerous electrical shock could result. The unit must only be disassembled and repaired by qualified service technicians.
- If damage to this unit exposes any internal parts, immediately disconnect the telephone line and mains supply. Then return the unit to a servicenter.
- Never attempt to insert wires, pins, etc. into the vents or other holes of this unit.

WARNING:

TO PREVENT POSSIBLE FIRE OR ELECTRIC SHOCK, DO NOT EXPOSE THIS PRODUCT TO RAIN OR MOISTURE. THIS HANDSET EARPIECE IS MAGNETIZED AND MAY RETAIN SMALL FERROUS OBJECTS.

DISCONNECT THE TELEPHONE LINE CORD FROM THIS PRODUCT IF THIS PRODUCT EMITS SMOKE, AN ABNORMAL SMELL OR MAKES UNUSUAL NOISE.

THESE CONDITIONS CAN CAUSE FIRE OR ELECTRIC SHOCK. CONFIRM THAT SMOKE HAS STOPPED AND CONTACT AN AUTHORIZED SERVICENTER.

IMPORTANT NOTICE:

Under power failure conditions, this telephone may not operate. Please ensure that a separate telephone, not dependent on local power, is available for use in an emergency.

Included Accessories: (for extra orders, call toll free 1-800-332-5368)

- | | |
|-----------------------------------|----------------------------|
| • Handset 1 | • Handset Cord 1 |
| • Telephone Line Cord 1 | • Stand 1 |





Please read other important information on pages 11-13 before use.

Features List

- Outside (CO) Line button
 Off-hook
 On-hook
 Feature number
 Talk
 (ICD Group) Incoming Call Distribution Group button
 (DSS) Direct Station Selection button
 C. Tone Confirmation Tone
 R.B. Tone Ringback Tone

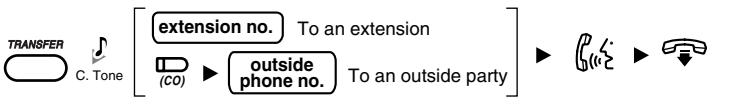

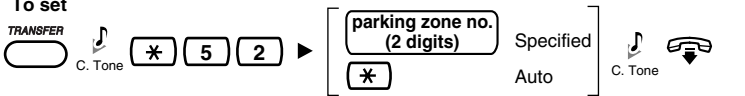
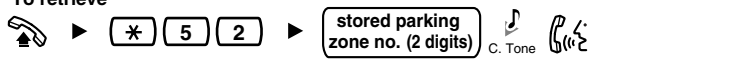
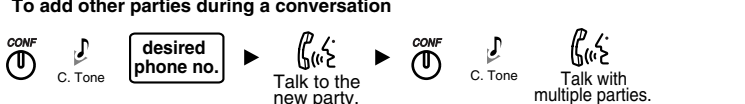

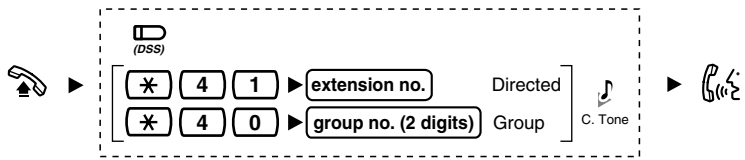
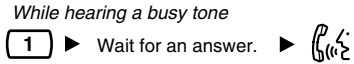
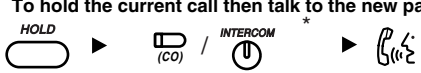















Feature	Operation
Making Calls	
Calling	<p>To an extension</p> ► extension no. ►
Redial	► REDIAL ►
Quick Dialing	► quick dial no. ►
One-touch Dialing	<p>To store</p> ► ► 2 ► desired no. (max. 32 digits) ► ►
	<p>To dial</p> ► assigned as a One-touch Dialing button ►
Operator Call	► 0 ►
Personal Speed Dialing	<p>To store</p> ► * 3 0 ► personal speed dial no. (2 digits) ► desired no. (max. 32 digits) ► #
	<p>To dial</p> ► ► * ► personal speed dial no. (2 digits) ►
System Speed Dialing	<p>To dial</p> ► ► system speed dial no. (3 digits) ►
Doorphone Call	► * 3 1 ► doorphone no. (2 digits)
Automatic Callback Busy	<p>To set</p> <p><i>While hearing a busy tone</i></p>
	<p>To answer from an idle extension</p> <p><i>While hearing a callback ring</i></p>
	<p>To cancel</p> ► * 4 6
	<p>To answer from an idle outside line</p> <p><i>While hearing a callback ring</i></p> ► outside phone no. ►
During a Conversation	
Call Hold	<p>To hold</p>
	<p>To retrieve a call at the holding extension</p> ► / / ►
	<p>To retrieve an outside call from another extension</p> ► ►

Features List



























Feature	Operation
During a Conversation	
Call Transfer	
Useful Features	
Off-hook Monitor	<p>To set/cancel <i>During a conversation using the handset</i></p> 
Call Park	<p>To set</p> 
	<p>To retrieve</p> 
Multiple Party Conversation	<p>To add other parties during a conversation</p>  <p>Talk to the new party. Talk with multiple parties.</p>
	<p>To leave a conference</p> 
Call Pickup	
Sending a Call Waiting Tone	<p><i>While hearing a busy tone</i></p> 
Answering a Call Waiting	<p>To hold the current call then talk to the new party</p> 

* Disregard this step if both parties are extensions.

Features List

Feature	Operation
Useful Features	
Paging	<p>To page</p>  ▶ * 3 3 ▶ paging group no. (2 digits) C. Tone  ▶ Wait for an answer. C. Tone 
	<p>To answer</p>  ▶ * 4 3 C. Tone 
	<p>To allow/deny a paged announcement</p>  ▶ * 7 2 1 1 Deny * 7 2 1 0 Allow C. Tone 
Message Waiting	<p>Caller</p> <p>To leave a message waiting indication <i>When the called extension is busy or does not answer</i></p>  C. Tone 
	<p>Called extension</p> <p>To call back</p>  ▶  ▶ 
Log-in/Log-out	 ▶ * 7 3 6 1 For Log-in * 7 3 6 0 For Log-out ▶ ICD Group extension no. Specified * All C. Tone 
Before Leaving Your Desk	
Setting Absent Message	<p>To set</p>  ▶ * 7 5 0 ▶ message no. (1-9) ▶ parameter (if required) ▶ # ▶ 
	<p>To cancel</p>  ▶ * 7 5 0 0 ▶ 
Call Forwarding	 ▶ * 7 1 ▶ 0 Both Calls 1 Outside Calls 2 Intercom Calls ▶
	<div style="border: 1px dashed black; padding: 10px;">  ▶ 2 All calls 3 Busy 4 No answer 5 Busy/ No answer 0 Cancel ▶ extension no. OR CO line access no. ▶ outside phone no. ▶ # C. Tone  </div>

Features List

Feature	Operation										
Before Leaving Your Desk											
Extension Dial Lock	To lock  ► * 7 7 1  										
	To unlock  ► * 7 7 0 ► extension PIN* (max. 10 digits)   <small>*PIN: Personal Identification Number</small>										
Setting the Telephone According to Your Needs											
Do Not Disturb	 ► * 7 1 ► <table border="1" style="display: inline-table; vertical-align: middle;"> <tr><td>0</td><td>Both Calls</td></tr> <tr><td>1</td><td>Outside Calls</td></tr> <tr><td>2</td><td>Intercom Calls</td></tr> </table> ► <table border="1" style="display: inline-table; vertical-align: middle;"> <tr><td>1</td><td>Set</td></tr> <tr><td>0</td><td>Cancel</td></tr> </table>  	0	Both Calls	1	Outside Calls	2	Intercom Calls	1	Set	0	Cancel
0	Both Calls										
1	Outside Calls										
2	Intercom Calls										
1	Set										
0	Cancel										
Extension Feature Clear	 ► * 7 9 0  										
Timed Reminder	To set  ► * 7 6 0 1 ► hour/minute (4 digits) ► <table border="1" style="display: inline-table; vertical-align: middle;"> <tr><td>0</td><td>AM</td></tr> <tr><td colspan="2" style="text-align: center;">OR</td></tr> <tr><td>1</td><td>PM</td></tr> </table> ► ► <table border="1" style="display: inline-table; vertical-align: middle;"> <tr><td>0</td><td>once</td></tr> <tr><td>1</td><td>daily</td></tr> </table>  	0	AM	OR		1	PM	0	once	1	daily
	0	AM									
OR											
1	PM										
0	once										
1	daily										
To cancel  ► * 7 6 0 0  	To stop or answer the ring back  / 										
Receiving Call Waiting	To set/cancel for intercom calls  ► * 7 3 1 ► <table border="1" style="display: inline-table; vertical-align: middle;"> <tr><td>0</td><td>No Call</td></tr> <tr><td>1</td><td>Tone</td></tr> <tr><td>3</td><td>Whisper OHCA</td></tr> </table>  	0	No Call	1	Tone	3	Whisper OHCA				
	0	No Call									
1	Tone										
3	Whisper OHCA										
To set/cancel for outside calls  ► * 7 3 2 ► <table border="1" style="display: inline-table; vertical-align: middle;"> <tr><td>0</td><td>No tone</td></tr> <tr><td>1</td><td>Tone</td></tr> </table>  	0	No tone	1	Tone							
0	No tone										
1	Tone										



- For more details, refer to the Business Telephone System User Manual or consult your dealer.
- You can change the flexible CO buttons to the feature buttons.
- “Location of Controls” is shown on pages 7-8.

Settings on the Programming Mode

To enter the program mode		To exit	
PROGRAM ○		PROGRAM ○	
Operation			
Loop-CO (L-CO)	► ► (AUTO DIAL STORE)	FWD/DND - Both calls	► 4 1 ► (AUTO DIAL STORE)
Single-CO (S-CO)	► 0 CO line no. ► (AUTO DIAL STORE)	FWD/DND - Outside calls	► 4 2 ► (AUTO DIAL STORE)
Direct Station Selection	► 1 extension no. ► (AUTO DIAL STORE)	FWD/DND - Intercom calls	► 4 3 ► (AUTO DIAL STORE)
One-touch Dialing	► 2 desired no. ► (AUTO DIAL STORE)	Account	► 4 8 ► (AUTO DIAL STORE)
Incoming Call Distribution Group (ICD Group)	► 3 0 ► ICD Group no. ► (AUTO DIAL STORE)	Conference	► 4 9 ► (AUTO DIAL STORE)
		Log in/ Log-out	► 5 5 ► (AUTO DIAL STORE)
Preferred Line Assignment-Outgoing	1 9 ► (AUTO DIAL STORE) ►	0 No line 1 An idle outside line 2 + CO button no. / A CO/ICD Group button 3 / INTERCOM Intercom	(AUTO DIAL STORE)
Preferred Line Assignment-Incoming	2 0 ► (AUTO DIAL STORE) ►	0 No line 1 The longest ringing line 2 + CO button no. / An assigned outside button	(AUTO DIAL STORE)
Alternate Receiving-Ring/Voice	2 1 ► (AUTO DIAL STORE) ►	0 Ringing (Tone Call) 1 Directly (Voice Call) 2 Ring only	(AUTO DIAL STORE)
Call Waiting for Outside calls	3 0 ► (AUTO DIAL STORE) ►	0 No (No tone) / 1 Yes (Tone)	(AUTO DIAL STORE)
Call Waiting Selection	3 1 ► (AUTO DIAL STORE) ►	0 No Call / 1 Tone / 3 Whisper OHCA	(AUTO DIAL STORE)
Call Waiting Tone Type Selection	3 2 ► (AUTO DIAL STORE) ►	0 Tone 1 / 1 Tone 2	(AUTO DIAL STORE)
Extension PIN [Personal Identification Number] (PIN-max.10 digits)	9 0 ► (AUTO DIAL STORE) ►	To set an extension PIN [extension PIN ► (AUTO DIAL STORE) ► same PIN]	(AUTO DIAL STORE)
		To change a stored extension PIN to new one [stored extension PIN ► new PIN ► (AUTO DIAL STORE) ► same PIN]	
Station Programming Data Default Set	# # ► (AUTO DIAL STORE) ► (AUTO DIAL STORE)		

Location of Controls

LCD (Liquid Crystal Display) with Backlight

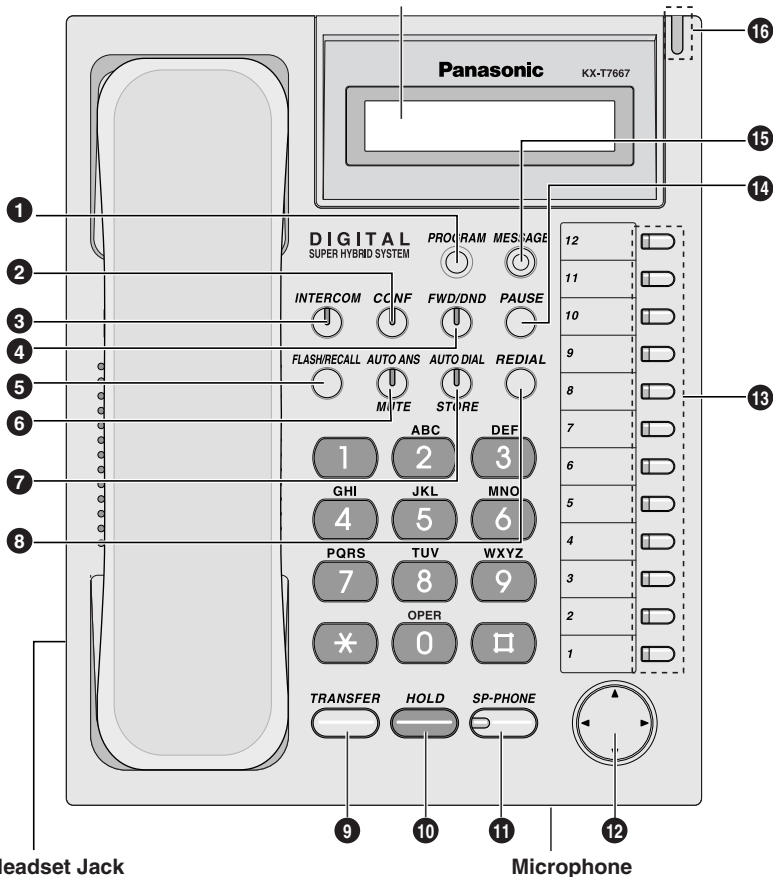

Headset Jack

Microphone

- 1 **PROGRAM:** Used to enter and exit the personal programming mode.
- 2 **CONF (Conference):** Used to establish a multiple party conversation.
- 3 **INTERCOM:** Used to make or receive intercom calls.
- 4 **FWD/DND (Call Forwarding/Do Not Disturb):** Used to perform Call Forwarding or Do Not Disturb.
- 5 **FLASH/RECALL:** Used to disconnect the current call and make another call without hanging up.
- 6 **AUTO ANS (Auto Answer)/MUTE:** Used to receive an incoming call in hands-free mode or mute the microphone/handset during a conversation.
- 7 **AUTO DIAL/STORE:** Used for System/Personal Speed Dialing or storing program changes.
- 8 **REDIAL:** Used to redial the last dialed number.
- 9 **TRANSFER:** Used to transfer a call to another party.
- 10 **HOLD:** Used to place a call on hold.

Location of Controls

- 11 **SP-PHONE (Speakerphone):** Used for the hands-free operation.
- 12 **Navigator Key:** Used to adjust the volume and select desired items for each function.
- 13 **Flexible Outside (CO) Line Button:** Used to make or receive an outside call. Pressing this button seizes an idle outside line automatically. (Button assignment is required.) Also used as feature buttons. (Button assignment is required.)
- 14 **PAUSE:** Used to insert a pause during dialing.
- 15 **MESSAGE:** Used to leave a message waiting indication or call back the party who left the message waiting indication.
- 16 **Message/Ringer Lamp:** When you receive a call, the lamp flashes red. When someone has left you a message, the lamp stays on red.

◆◆ Setting

◆ Speaker/Ringer/Handset/Headset Volume

Speaker Volume	While in hands-free conversation	 Press UP or DOWN.
Ringer Volume	While on-hook or receiving a call	
Handset/Headset Volume	While using the handset or headset	

◆ LCD Contrast/Headset Mode

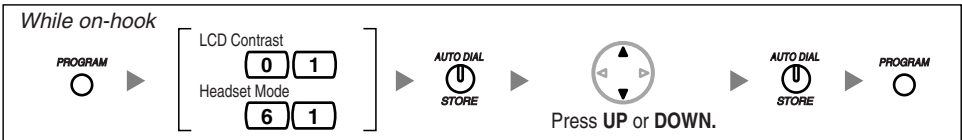

◆ Ring Tone

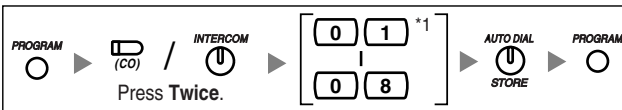

*1 The ring tone pattern of patterns 09 to 30 is the same as pattern 01.

◆ LCD Backlight

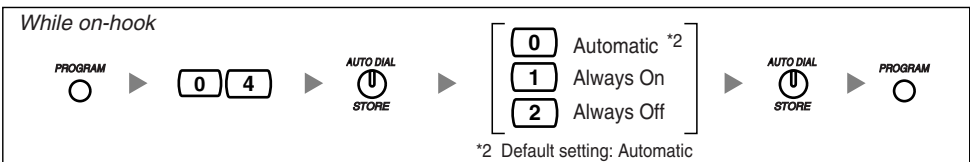

Tilt Angle

The tilt angle of the unit can be adjusted.

To adjust the angle, insert the stand into the desired holes as shown below.

< LOW >

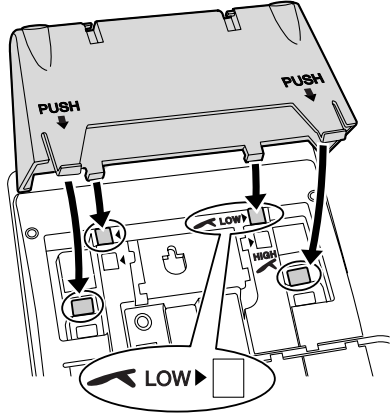
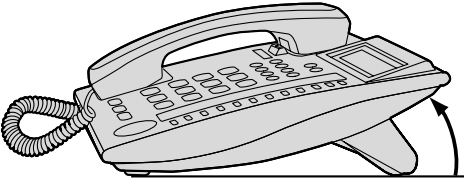

< HIGH >

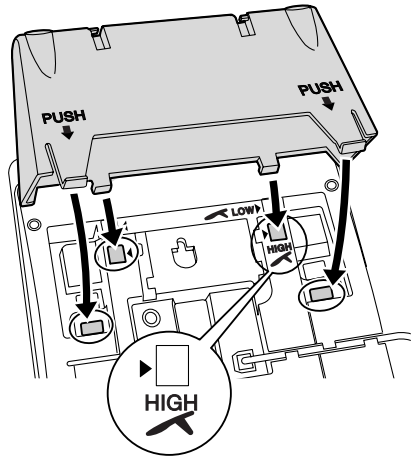
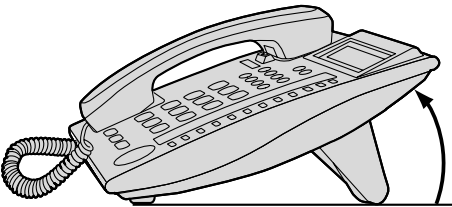

Connection

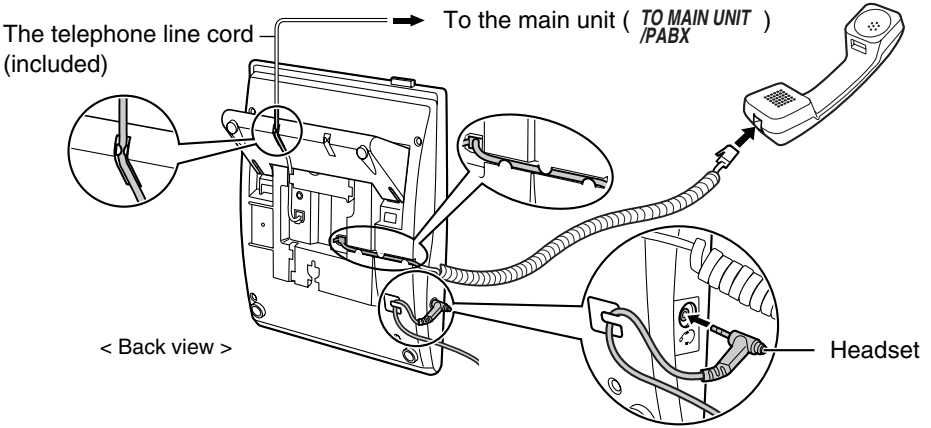

CAUTION

Ensure the cord is inserted in the groove to prevent damage to the connector.

Headset (not included)
 Recommendable: KX-TCA86, KX-TCA91, KX-TCA92
 Not compatible: KX-T7090

Wall Mounting

1 Pull down the handset hook until it locks, so the tab holds the handset.

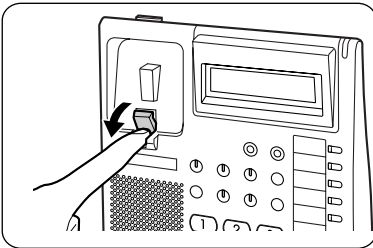

3 Mount the unit on the wall.

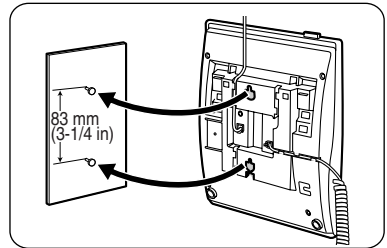

2 Remove the attached stand.

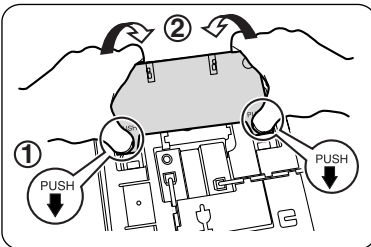

To temporarily place the handset down during a conversation, hook it over the top edge of the phone as shown.

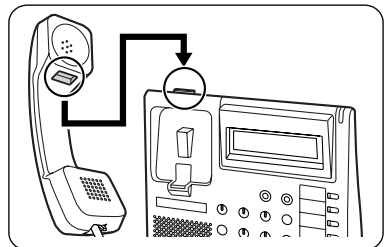

Important Safety Instructions

When using this unit, basic safety precautions, including those below, should always be followed to reduce the risk of fire, electric shock and injury to persons.

1. Read and understand all instructions.
2. Follow all warnings and instructions marked on this unit.
3. Unplug this unit from the main unit before cleaning. Do not use liquid or aerosol cleaners. Clean with a damp cloth.
4. Do not use the unit near water, for example, near a bathtub, kitchen sink, or laundry tub, in a wet basement, or near a swimming pool.
5. Place this unit on a flat surface. Serious damage and/or injury may result if the unit falls.
6. The unit should never be placed near or over a radiator or other heat source.
7. Do not allow anything to rest on the extension cord. Do not locate this unit where the cord may be stepped on or tripped on.
8. To reduce the risk of fire or electric shock, do not overload wall outlets and extension cords.
9. Do not insert objects of any kind into this unit through openings, as they may touch dangerous voltage points or short out parts that could result in a risk of fire or electric shock. Never spill liquid of any kind on the unit.
10. To reduce the risk of electric shock, do not disassemble this unit. Only qualified personnel should service this unit. Opening or removing covers may expose you to dangerous voltages or other risks. Incorrect reassembly can cause electric shock.
11. Unplug this unit from the main unit and have the unit serviced by qualified service personnel in the following cases:
 - A. When the extension cord is damaged or frayed.
 - B. If liquid has been spilled on the unit.
 - C. If the unit has been exposed to rain or water.
 - D. If the unit does not work normally by following the manual. Adjust only controls covered by the manual. Improper adjustment may require repair by an authorized servicenter.
 - E. If the unit has been dropped, or damaged.
 - F. If the unit's performance deteriorates.
12. Avoid using a telephone (other than a cordless type) during an electrical storm. There is a remote risk of electric shock from lightning.
13. Do not use the telephone in the vicinity of a gas leak to report the leak.

**SAVE THESE
INSTRUCTIONS**

FCC Information

NOTE:

This equipment has been tested and found to comply with the limits for a Class B digital device, pursuant to Part 15 of the FCC Rules. These limits are designed to provide reasonable protection against harmful interference in a residential installation. This equipment generates, uses, and can radiate radio frequency energy and, if not installed and used in accordance with the instructions, may cause harmful interference to radio communications. However, there is no guarantee that interference will not occur in a particular installation. If this equipment does cause harmful interference to radio or television reception, which can be determined by turning the equipment off and on, the user is encouraged to try to correct the interference by one or more of the following measures:

- Reorient or relocate the receiving antenna.
- Increase the separation between the equipment and receiver.
- Connect the equipment to an outlet on a circuit different from that to which the receiver is connected.
- Consult the dealer or an experienced radio/TV technician for help.

CAUTION:

To assure continued compliance with FCC rules, do not make any unauthorized changes or modifications to this equipment would void the user's authority to operate this device.

When programming emergency numbers and/or making test calls to emergency numbers:

- 1) Remain on the line and briefly explain to the dispatcher the reason for the call before hanging up.
- 2) Perform such activities in the off peak hours, such as early morning hours or late evenings.

Customer Information

This equipment complies with Part 68 of the FCC rules and the requirements adopted by the ACTA. On the bottom of the cabinet of this equipment is a label that contains, among other information, a product identifier in the format US: AAAEQ##Txxxx. If requested, this number must be provided to the telephone company.

If trouble is experienced with this equipment KX-T7667, for repair or warranty information, please contact:

Panasonic Services Company
BTS Center
1225 Northbrook Parkway Suite
1-216 Suwanee
GA 30024

If the equipment is causing harm to the telephone network, the telephone company may request that you disconnect the equipment until the problem is resolved.

Hearing Aid Compatibility:

This telephone provides magnetic coupling for hearing aids.

Use only handsets or other acoustic devices with this equipment that are compliant with the hearing aid compatibility requirements of FCC Part 68.

Other Important Information

When you ship the product:

Carefully pack and send it prepaid, adequately insured and preferably in the original carton. Attach a postage-paid letter, detailing the symptom to the outside of the carton.

DO NOT send the product to the Executive or Regional Sales offices. They are NOT equipped to make repairs.

Product service:

Panasonic Servicenters for this product are listed in the servicenter directory. Consult your certified Panasonic dealer for detailed instructions.

Note

Note

For your future reference

SERIAL NO. _____ DATE OF PURCHASE _____
(found on the bottom of the unit)

NAME OF DEALER _____

DEALER'S ADDRESS _____

DEALER'S TEL. NO. _____

Copyright:

This material is copyrighted by Panasonic Communications Co., Ltd., and may be reproduced for internal use only. All other reproduction, in whole or in part, is prohibited without the written consent of Panasonic Communications Co., Ltd.

©2006 Panasonic Communications Co., Ltd. All Rights Reserved.

Panasonic Consumer Electronics Company,
Division of Panasonic Corporation of North America
One Panasonic Way, Secaucus, New Jersey 07094

Panasonic Puerto Rico, Inc.
San Gabriel Industrial Park, Ave. 65 de Infantería, Km. 9.5,
Carolina, Puerto Rico 00985

<http://www.panasonic.com/csd>

PSQX4167ZA-BM KK0506SY0(M)